



nectre.

N15

OPERATING INSTRUCTIONS

EFFICIENT • WARM • FRIENDLY



NECTRE N15 LEGS



NECTRE N15 PEDESTAL



NECTRE N15 WOODSTACKER



Australian Home Heating
Association Inc.



Landcare
Australia

Glen Dimplex Australia proudly supports the activities of Landcare Australia through its membership of the AHHA.

TABLE OF CONTENTS

USER INSTRUCTIONS

1. Introduction	2
1.1. Air Controls	2
1.2. Air Wash	2
1.3. Door Handle	3
1.4. Wood Storage Compartment	3
2. Using Appliance for the First Time	3
3. Recommended Fuels	3
4. Lighting the Fire	4
5. Running the Appliance	4
5.1. High Heat Output	4
5.2. Low Heat Output	4
5.3. Reload with More Wood	4
6. Burning Tips	4
6.1. Fuel Quality	4
6.2. Flue Draught	5
7. Ash Removal	5
8. Flue/Chimney Fire	5
9. Cleaning Paintwork and Glass	5
10. Cleaning the Flue	5
11. Troubleshooting Tips	6
11.1. Glass in Door Blackening	6
11.2. Trouble Starting the Fire	6
11.3. Insufficient Flue Draft	6
11.4. Burning Too Quickly	6
11.5. Glass Cracking	6

MAINTENANCE AND SERVICING

1. Replacement of Fire Bricks	7
2. Replacement of Brick Retainer	7
3. Replacement of Baffle Plates	7
4. Fitting New Door Glass	8
5. Fitting a New Door Seal	8
6. Adjusting Door Latch	9
7. Replacement Spare Parts List	10
8. Warranty	11

USER INSTRUCTIONS

1. INTRODUCTION

Before use of this appliance please read these instructions fully.

WARNING: ANY MODIFICATION OF THE APPLIANCE THAT HAS NOT BEEN APPROVED IN WRITING BY THE TESTING AUTHORITY IS CONSIDERED AS BREACHING AS/NZS 4013.

WARNING: DO NOT USE FLAMMABLE LIQUIDS OR AEROSOLS TO START OR REKINDLE THE FIRE.

WARNING: DO NOT USE FLAMMABLE LIQUIDS OR AEROSOLS IN THE VICINITY OF THIS APPLIANCE WHEN IT IS OPERATING.

WARNING: DO NOT STORE FUEL WITHIN HEATER INSTALLATION CLEARANCES.

WARNING: WHEN OPERATING THIS APPLIANCE AS AN OPEN FIRE USE A FIRE SCREEN.

WARNING: OPEN AIR CONTROL BEFORE OPENING DOOR.

WARNING: DO NOT BURN WOOD THAT IS PAINTED; OR IS COATED WITH PLASTIC; OR HAS BEEN TREATED WITH ANY CHEMICAL.

CAUTION: THIS APPLIANCE SHOULD NOT BE OPERATED WITH CRACKED GLASS.

CAUTION: THIS APPLIANCE SHOULD BE MAINTAINED AND OPERATED AT ALL TIMES IN ACCORDANCE WITH THESE INSTRUCTIONS.

The appliance or flue system should not be modified in any way without the written approval of the manufacturer.

Extraction fans or rangehoods must not be placed in the same room or space, as this can cause appliance to emit smoke into the room.

1.1. AIR CONTROLS

The Nectre N15 has a single air control for controlling the burn rate of the fire. It allows air to enter the firebox at the base of the fire.

The air control is operated by rotating the spindle located on the door. Rotate counter clockwise for maximum burn rate, and rotate clockwise until it stops to close off this air supply for minimum burn rate.

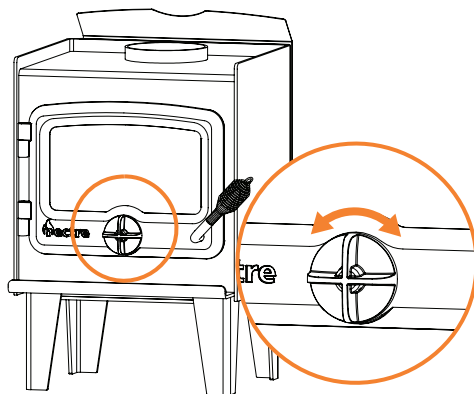

A tool for opening and closing the air spindle is supplied with the heater. This can be used in instances when the spindle control is too hot to touch. Alternatively, a glove or equivalent can be used to adjust the air spindle.

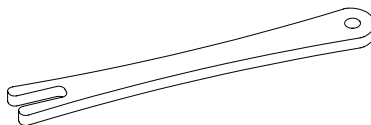

Secondary air holes in the rear of the firebox provide additional oxygen for more complete combustion of the gases released from the burning wood.

1.2. AIR WASH

A 2mm gap at the top of the door allows additional air to enter the firebox, washing over the door glass keeping it clean while also supplying necessary oxygen to the fire when the air spindle has been fully closed.

If the draft is too high or low with the spindle completely shut, the 2mm gap can be adjusted by loosening the two adjustment screws in the top of the door (highlighted in the diagram below) with the hex key supplied, adjusting the metal strip accordingly and re-tightening the screws.

For example, an installation in a two-storey house with a tall flue could have a very high draft. To reduce the draft, the gap on top of the door could be reduced to 1mm.

Warning: Do not close this air gap completely as it will restrict the draft too much. If it is too restricted, the fire will produce a lot of smoke and cause the glass to blacken.

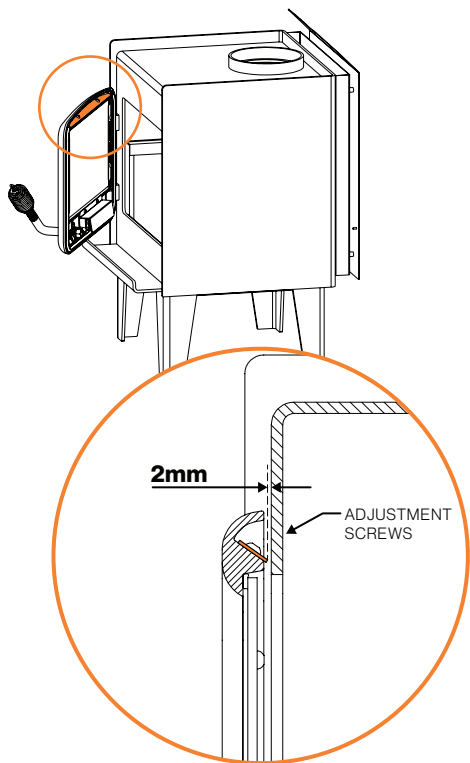

1.3. DOOR HANDLE

Warning: door handle may get hot if appliance has been left in High burn setting for an extended period of time. Use a protective glove to open if it is too hot to handle.

Open the air spindle before opening the door to eliminate the chance of backdraft and/or smoke entering the room.

1.4. WOOD STORAGE COMPARTMENT

Warning: the Nectre N15 Woodstacker features a storage area for a small amount of firewood. Do not overload this compartment - ensure that there is a gap of 20mm to the ceiling of the unit, 10mm to the sides, and no combustible fuel forward of the storage area.

2. USING APPLIANCE FOR THE FIRST TIME

The first few times the appliance is lit, it will give off some odorous fumes. This is caused by the paint curing.

Do not touch the paint work while it is curing otherwise it can leave a permanent mark on the appliance.

Once the paint has cured it will not re-occur.

Keep the room well ventilated until fumes have cleared.

3. RECOMMENDED FUELS

Burn only seasoned hardwood timber with a moisture content of less than 20%. Newly cut wood should be allowed to dry/season for 12 to 18 months before use.

Wood should be stored in an environment protected from the weather to minimize any potential moisture content.

For best results, wood should not exceed 250mm length and 150mm diameter. Any larger, and the appliance will not operate at its optimum. It is better to burn several smaller pieces of wood than one large single piece.

Poor quality timber:

- Causes low combustion efficiency
- Produces poor emissions (smoky)
- Results in additional buildup of creosote (soot) in the flue which will then require regular cleaning and may result in a flue fire.

Do not burn painted, impregnated/treated wood, manufactured board products or pallet wood.

4. LIGHTING THE FIRE

1. Place firelighters and/or paper and dry kindling wood in the base of the firebox.
2. Open spindle – rotate all the way counter clockwise.
3. Light the paper or firelighters.
4. If necessary, leave the door slightly open as the fire establishes and the glass warms to avoid a build-up of condensation.
5. Once the fire has taken hold add larger pieces of wood. For optimal burn conditions, place the logs in a front to back orientation (right angles to the door opening). Too many logs may smother the fire.
6. Once the fire is established, close the door.

Do not leave fire unattended while the door is open.

5. RUNNING THE APPLIANCE

5.1. HIGH HEAT OUTPUT

After establishing the fire and loading it with larger pieces of wood, leave it running with the spindle fully open.

Running the appliance with the door open will not produce maximum heating in the room as it will draw a lot of already warmed air out of the room.

Note that this setting is not the most energy efficient as some heat is lost up the flue instead of being transferred into the room.

Do not overload firebox with fuel.

5.2. LOW HEAT OUTPUT

The heat output of the appliance can be reduced by closing the spindle (rotate clockwise) which will restrict the oxygen supplied to the fire thereby slowing down the rate at which the wood burns.

This setting will provide the best energy efficiency as the wood burns for longer. However, if not operated correctly may result in higher particulate emissions.

Prior to closing the spindle ensure that the fire is burning briskly. This may require leaving the spindle fully open for

5-10 mins before shutting down.

For the optimum between clean burning, and getting the best in efficiency from the heater, from the fully closed position, open the spindle between half and one turn.

The air slide can be adjusted to any position so desired depending on wanted heat output versus burn time.

5.3. RELOAD WITH MORE WOOD

1. Open the spindle before opening door.
2. Rake / break up any existing coals.
3. Load the wood with the length orientated front to back.
4. Better results will be achieved by loading several smaller pieces of wood rather than one large piece.
5. Close door with spindle fully open, and leave for minimum of 10 minutes to allow fresh wood to catch.
6. After 10 or more minutes, the spindle can be adjusted to the desired heat output setting.

6. BURNING TIPS

6.1. FUEL QUALITY

Use wood with a moisture content of less than 20%. Logs should not feel moist/damp, or have moss/fungal growths.

Symptoms related to wet wood:

- Difficulty starting and keeping a fire burning well.
- Smoke and only small flames.
- Dirty glass and/or fire bricks.
- Rapid creosote build-up in the flue/chimney.
- Low heat output.
- Short burn times, and blue/grey smoke from the flue/chimney outlet.

Run appliance at high heat output for a short period each day to avoid large build-up of tars and creosote within the appliance and flue.

6.2. FLUE DRAUGHT

The flue has two main functions:

1. To safely remove smoke, gases and fumes from the appliance.
2. To provide a sufficient amount of draught (suction) in the appliance to ensure the fire keeps burning.

Draught is caused by the rising hot air in the flue when the fire has been lit. The position, height and size of the flue can affect the performance of the flue draught. Refer to installation guide for details on flue installation.

Factors affecting the flue draught include:

- Insufficient flue height
- Trees or other buildings nearby causing turbulence
- High and gusty winds
- Outside temperature and weather conditions
- Blocked flue

For advice on the correction of persistent flue problems consult your supplier/installer for more detail.

7. ASH REMOVAL

Depending on the type of wood burnt and frequency, the ashes will need removing every 2 to 6 weeks.

Retaining at least 10mm of ash helps protect the firebox base, and can make it easier to start the fire next time.

Excess ashes should be removed when necessary, placed in a non-combustible container with a tightly fitting lid and moved outdoors immediately to a location clear of combustible materials.

8. FLUE/CHIMNEY FIRE

If a flue/chimney fire occurs:

- Shut spindle fully to smother the fire.
- Do not use the appliance after a flue fire until an accredited installer has assessed the cause and any resultant damage.

9. CLEANING PAINTWORK AND GLASS

The heater, when cool, can be cleaned with a damp cloth.

Over the years, the black paint will fade and can be touched up with Stove Bright metallic black paint.

To clean the glass, we recommend using a household window cleaner or general purpose cleaner with a soft cloth. Do not use abrasive cleaner or scourer pads.

10. CLEANING THE FLUE

Check inside of flue prior to each season for any build-up of creosote (wood tar). To do this:

1. First remove the baffle plate (refer to "3. Replacement of Baffle Plate").
2. Using a small mirror and torch hold the mirror on an angle below the flue with the torch shining at it and look for black creosote build-up. A fine black powdery layer is normal, but if built up layers of creosote can be seen, then the flue needs cleaning.
3. Refit the baffle if no cleaning is required.

To clean the flue:

1. A flue cleaning brush can be purchased from most wood heater retail outlets or large hardware stores.
2. The objective is to pull brush down through the flue.
3. With the baffle removed, tie a rope to one end of the brush, and drop the rope from the top (outside on top of the roof) down the flue.
4. Grab the end of the rope inside the firebox and pull the brush through.
5. Check the inside of the flue with the mirror and torch. Repeat if necessary.
6. Once clean, remove any excess creosote from the firebox and replace the baffle.

Check flue integrity by checking that the 900mm flue sections have not separated at the joints.

Alternatively, get a flue cleaning service to do the job for you (it's a dirty job).

11. TROUBLESHOOTING TIPS

11.1. GLASS IN DOOR BLACKENING

This can have several possible causes:

- Air wash gap has reduced — this can happen once the door seal has settled in. The gap at the top of the door should be 2mm. This can be checked with the hex key provided, as it is 2mm thick. If adjustment is required, loosen the two screws on the top of the door with the hex key, adjust the position of the metal strip and re-tighten the screws.
- Burning unseasoned wood — if the wood is too wet, it will cause the glass to blacken.
- Appliance operated at low temperature — after an overnight burn where the spindle has been fully closed, the glass may have blackened. When the fire is re-stoked and burning on the high heat setting, the blackened glass should self-clean.
- Problems with the flue — insufficient flue draught can cause the glass to blacken. If the flue is too short, not properly insulated, or in a position that results in a downdraught, then there will be insufficient flue draught. Contact the installer should this happen.

11.2. TROUBLE STARTING THE FIRE

If all ash has been removed from the firebox, it can upset the supply of air to the base of the fire. When cleaning out the firebox, retaining some ash can make it easier to start the fire next time.

11.3. INSUFFICIENT FLUE DRAFT

If there is insufficient or too much draft when air spindle is fully closed, i.e. the fire smokes and goes out, or burns too quickly, then the 2mm gap at the top of the door can be adjusted accordingly (refer "1.2. Air Wash" on page 2).

A larger gap will provide more oxygen to the fire, burning cleaner and faster.

A smaller gap will restrict oxygen to the fire, slowing down the burn rate. Note if the gap is too small the fire will smoke, and potentially upset neighbours.

11.4. BURNING TOO QUICKLY

If you find that the heater is burning through wood too quickly, it could be due to one or a combination of the below factors:

1. Latch needs adjustment (refer to "6. Adjusting Door Latch")
2. Door seal needs replacing (refer to "5. Fitting a New Door Seal")
3. Baffle needs replacing (refer to "3. Replacement of Baffle Plate")

11.5. GLASS CRACKING

Do not over tighten the screws on the stainless steel strips that hold the door glass in place. Otherwise, expansion of the cast iron door may cause the glass to crack.

MAINTENANCE AND SERVICING

1. REPLACEMENT OF FIRE BRICKS

The purpose of the firebricks in the appliance is to increase thermal mass and to guarantee the longevity of the steel firebox. Over time the firebricks may become cracked and crumble away. If so, they should be replaced.

To replace the firebricks:

1. Move any ash away from the bricks.
2. Raise the brick retainer and remove bricks.
3. Replace with new bricks, and refit the retainer which holds the bricks in place.

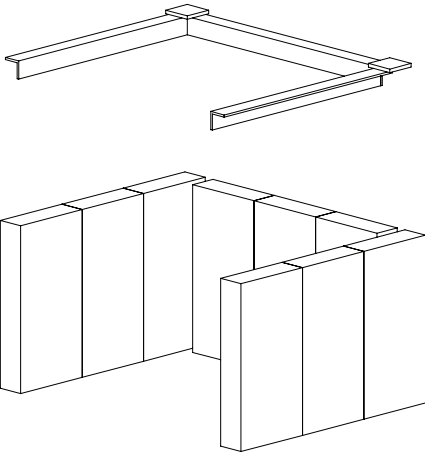

2. REPLACEMENT OF BRICK RETAINER

Over time the original brick retainer may burn out, in which case it can be replaced with a new one.

1. Remove bricks and old brick retainer from firebox.
2. Rotate the new brick retainer on a slight angle to get it through the door and into the firebox. While holding it up, refit the firebricks and then fit the retainer over the top locking them into position.

3. REPLACEMENT OF BAFFLE PLATE

The Nectre N15 is fitted with a thick steel baffle plate which helps to retain the heat in the firebox by lengthening the path of the flame as well as protect the firebox top.

Over time, the baffle plate may begin to sag a little due to the excessive heat. This will not affect the way the fire burns. Eventually the baffle plate will burn through (5+ years) and if so will need to be replaced.

Before the baffle plate can be removed, the firebricks need to be removed.

To remove the baffle plate:

1. Slide the baffle plate forward so that it can be lowered at the back.
2. Lowering the rear of the will allow the front to slide past the front support pins.
3. Once the baffle has cleared the front support pins, it can be removed from the firebox on an angle.
4. Repeat steps 1-3 in reverse to fit the new baffle.

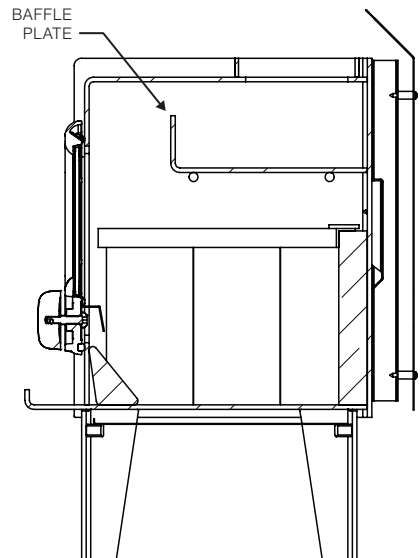

4. FITTING NEW DOOR GLASS

This task may be easier with the door removed from the appliance and laid horizontally on a work-bench.

To replace the door glass:

1. Two stainless steel strips hold the glass in place. Remove the four screws from the stainless steel strips with a 3mm hex key.

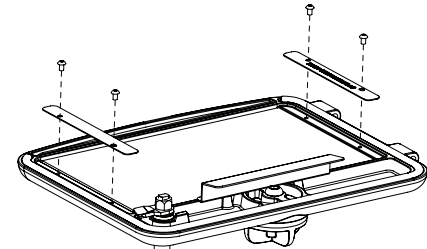

2. Take out the glass, and check if the grey rope beneath needs replacing. If so, replace this rope as well.

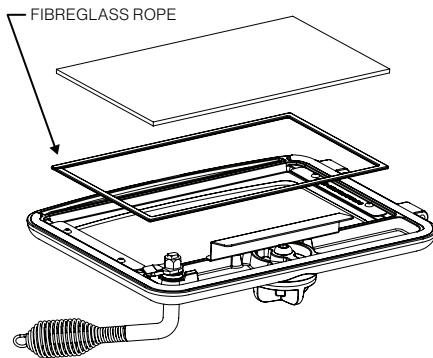

3. Position the new glass on top of the grey rope and re-fit the stainless steel strips and screws.
4. Take extra care not to over-tighten the screws, otherwise the glass will crack when the heater gets hot and the door expands.
5. Dispose of the old glass in a responsible manner.

5. FITTING A NEW DOOR SEAL

This task may be easier with the door removed from the appliance and laid horizontally on a work-bench.

1. Remove any old seal from the door.
2. Clean out the groove in the door that held the seal using a flat-end screw driver or equivalent.
3. Run a thin bead of clear roof and gutter silicone along the groove.
4. Starting at one end, press the new door seal rope into the groove on the door.
5. Refit the door if it has been removed and close.

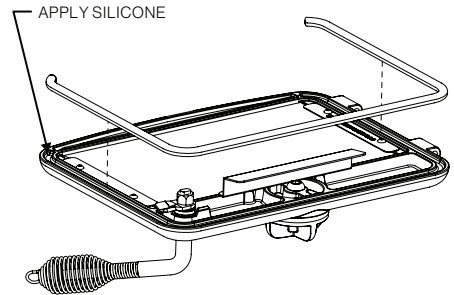

6. ADJUSTING DOOR LATCH

If the door does not close firmly, the latch can be adjusted.

The latch is fastened onto the door with two removable washers. Use a socket wrench to undo the M12 nut, then remove one of the washers directly beneath the nut.

Securely fasten latch assembly again.

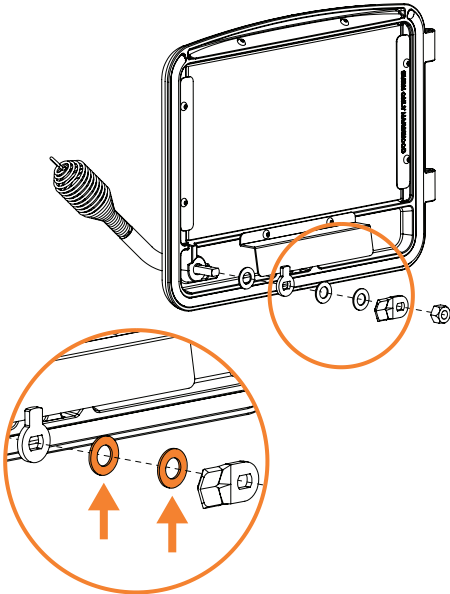

Close the door with the door handle to test for any improvement. If no improvement, remove second washer.

7. REPLACEMENT SPARE PARTS LIST

PART NO.	PART	DETAIL
N900-157	Fire Brick Set	9 @ 230 x 115 x 38mm
N900-159	Triangular Front Brick	1 @ 350mm
N100-021	Brick Retainer	420mm x 345mm
N100-014	Baffle Plate	440 x 260 x 75 x 6mm steel
N900-168	Door Seal	900mm x 13mm round
N900-169	Glass Seal	1080mm 8mm x 3mm flat adhesive backed
N900-034	Door Glass	333 x 195 x 5mm pyro ceramic
N100-059	Side Shield Kit (Legs/Ped)	1 x Left, 1 x Right to suit Legs/Ped
N100-058	Side Shield Kit (WS)	1 x Left, 1 x Right, 10x tapping screws to suit Woodstacker

8. WARRANTY

Warranty is provided in Australia by Glen Dimplex Australia Pty Ltd and in New Zealand by Glen Dimplex New Zealand Ltd (together referred as "Glen Dimplex").

This warranty is provided to the first domestic purchaser of a Nectre wood or Stove fire (radiant or convection). It applies for 10 years from the date of purchase from or through an authorized Nectre Fire Distributor in relation to each product.

The door glass, door seal, firebricks, brick retainer, and baffle components are covered for normal use only with a 1 (one) year warranty. Electric fans and any remote/transmitter are warranted against failure to operate for a period of 1 (one) year from the original date of purchase.

The warranty does not apply to discolouration of the surface or tarnishing of chrome fittings all of which require regular service to maintain. Any breakage or failure due to user error is not covered under this warranty.

TYPE OF PART	WARRANTY (IN YEARS)	
	PARTS	LABOUR
Wood Fire - Firebox	10	5
Door Glass & Seal	1	1
Fire Bricks & Retainer	1	1
Baffle Components	1	1
Fans & Electrical Components	1	1

During the warranty period, Glen Dimplex will repair or replace (at its option) any Nectre Wood or Stove Fire which is found to be defective in materials or workmanship. Repairs will be carried out by an approved Nectre Heating Service Agent.

What is covered under this warranty?

- Repair or replacement of parts
- Labour costs relating to the Wood or Stove Fire

Consumers may have additional rights under the Australian Trade Practices Act 1974 including the Australian Consumer Law or the Consumer Guarantees Act 1993 New Zealand.

This warranty does not apply and will be void where:

- The Wood or Stove Fire is not installed in accordance with AS/NZS 2918:2018 or any building code or consent;
- The Wood or Stove Fire is not installed by a qualified specialist installer;
- Any electrical work has not been carried out by a Registered Electrician;
- The Wood or Stove Fire has been moved and reinstalled, or has been modified in a manner that is not consistent with the Installation Guide or the Owner's Manual;
- The Wood or Stove Fire has not been installed or operated according to the Installation Guide and the Owner's Manual;
- The Wood or Stove Fire is acquired for business use in any way.

What is not covered?

- Labour costs relating exclusively to components not manufactured by Glen Dimplex.
- Labour costs relating to removing or replacing the Wood Fire or Stove
- Damage caused by incorrect use or the burning of treated or painted wood, driftwood or other fuels which are not recommended.
- Travel costs for a distance greater than 50 km from nearest approved Nectre Heating Service Agent.
- Defects, malfunctions or failures caused by incorrect installation, poor installation, normal wear and tear, misuse, neglect, accidental damage or failure to follow operating instructions in the Owner's Manual (including fuel selection, product operation and maintenance instructions), repairs

or modifications by persons not authorised by Glen Dimplex, use of parts not supplied by Glen Dimplex, or damage or other events which have occurred since the product left the control of Glen Dimplex.

- Removal or transportation of such product or part (and any repaired or replacement product or part) to and from the authorized dealer's or service agents place of business.
- Direct, indirect or consequential losses or special damages of any kind (including costs of collection and delivery) other than repair or replacement of products or components under this warranty, where any goods are acquired or used for the purposes of a business;

How to obtain warranty service?

- Warranty Claims must be made at place of purchase.
- Reasonable proof of purchase date is required to make a warranty claim. You should keep your purchase receipt.
- Warranty repair will be completed according to normal work practices of the service agent.
- Make the faulty part(s) available to Glen Dimplex for inspection so that the validity of the claim can be established by them.



Glen Dimplex Australia Pty Ltd

8 Lakeview Drive,
Scoresby Victoria 3179
Australia

T: 1300 554 155

General & Sales Enquiries: flame.care@glendimplex.com.au

Technical Service: flame.support@glendimplex.com.au

www.glendimplex.com.au