



blaze

B500
B800

INSTALLATION INSTRUCTIONS

Contemporary Styled Wood Heaters



BLAZE B500/B800



Glen Dimplex Australia proudly supports the activities of Landcare Australia through its membership of the AHHA.

VERSION 1.0

TABLE OF CONTENTS

- 1. Important Information. 2
- 2. Installing the Heater 2
 - 2.1. Positioning the Heater. 2
 - 2.2. Floor Protector (Hearth) 4
- 3. Reducing Clearances to Combustibles 4
- 4. Installing the Flue. 4
- 5. Installing the Flue (Continued) 6
 - 5.1. Locating Ring. 6
 - 5.2. Fitting Flue Seal 6
- 6. Installing the Ash Plate 6
- 7. Installing the Baffle Plate 6
- 8. Installing the Fire Bricks 7
- 9. Technical Drawings. 8
 - 9.1. B500 8
 - 9.2. B800 9

THE INSTALLATION INSTRUCTIONS IN THIS MANUAL APPLY TO THE BLAZE B500 & B800.

IT HAS BEEN TESTED FOR EMISSIONS AND EFFICIENCY AND COMPLIES ACCORDING TO AS/NZS 4012:2014 & AS/NZS 4013:2014.

INSTALLATION CLEARANCES WERE DETERMINED BY TESTING IN ACCORDANCE WITH AS/NZS 2918.

1. IMPORTANT INFORMATION

Most building regulatory authorities in Australia require any wood heater installation to comply with Installation Standard AS/NZS 2918:2018. Different states and councils may have varying regulations. Check local building regulations before installing the appliance.

All Blaze wood heaters have been tested to ensure that they will meet the appropriate safety Standard requirements if the instructions in this manual are followed. As the safety and emissions performance can be affected by altering the appliance, no modifications are allowed without written permission from the manufacturer.

WE RECOMMEND THAT THE INSTALLATION OF YOUR BLAZE WOOD HEATER BE CARRIED OUT BY A QUALIFIED INSTALLER.

WARNING: THE APPLIANCE AND FLUE SYSTEM SHALL BE INSTALLED IN ACCORDANCE WITH AS/NZS 2918:2018 AND THE APPROPRIATE REQUIREMENTS OF THE RELEVANT BUILDING CODE OR CODES.

WARNING: APPLIANCES INSTALLED IN ACCORDANCE WITH THIS STANDARD SHALL COMPLY WITH THE REQUIREMENTS OF AS/NZS 4012 & AS/NZS 4013 WHERE REQUIRED BY THE REGULATORY AUTHORITY, I.E. THE APPLIANCE SHALL BE IDENTIFIABLE BY A COMPLIANCE PLATE WITH THE MARKING 'TESTED TO AS/NZS 4012 & AS/NZS 4013'.

ANY MODIFICATION OF THE APPLIANCE THAT HAS NOT BEEN APPROVED IN WRITING BY THE TESTING AUTHORITY IS CONSIDERED TO BE IN BREACH OF THE APPROVAL GRANTED FOR COMPLIANCE WITH AS/NZS 4012 & AS/NZS 4013.

Caution: Mixing of appliance or flue-system components from different sources or modifying the dimensional specification of components may result in hazardous conditions. Where such action is considered, the manufacturer should be consulted in the first instance.

Caution: Cracked and broken components, e.g. glass panels or ceramic tiles, may render the installation unsafe.

2. INSTALLING THE HEATER

2.1. POSITIONING THE HEATER

First review the necessary **minimum** clearances specified on the following page before considering where to position the heater. These clearances can be greater if desired.

The heater can be installed with a choice of three different flue configurations. Also check the practicability of installing the flue system in relation to any obstructing roof beams before positioning the heater.

These clearance distances can only be reduced if the surrounding walls are made of non-combustible material, e.g. stone, brick, or concrete. In this circumstance, distance can be reduced to 100 mm. Alternatively, shielding of the wall(s) can reduce clearances (refer to next section for more detail).

2.1.1. STANDARD INSTALLATION

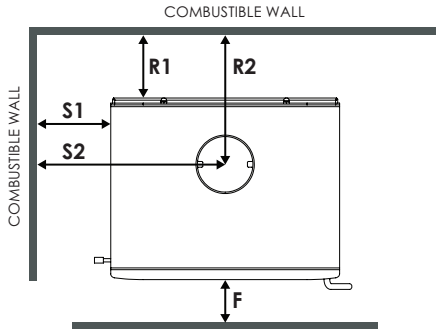

B500
STANDARD INSTALLATION

Side - S1	350mm
Side - S2	668mm
Rear - R1	125mm
Rear - R2	309mm
Floor - F	300mm

B800
STANDARD INSTALLATION

Side - S1	300mm
Side - S2	668mm
Rear - R1	125mm
Rear - R2	309mm
Floor - F	400mm

2.1.2. CORNER INSTALLATION

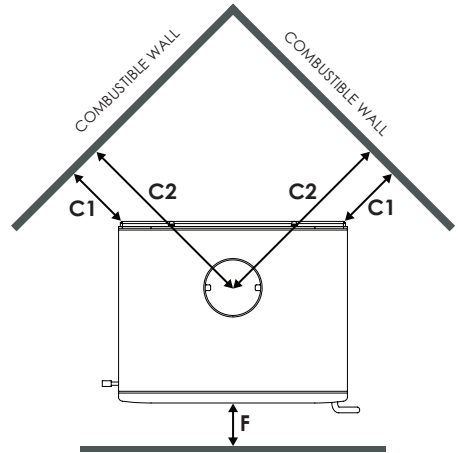

B500
CORNER INSTALLATION

Corner - C1	100mm
Corner - C2	449mm
Floor - F	300mm

B800
CORNER INSTALLATION

Corner - C1	100mm
Corner - C2	485mm
Floor - F	400mm

2.2. FLOOR PROTECTOR (HEARTH)

Unless the heater will be standing on a heat resistant floor such as concrete slab with slate or tiles, it will be necessary to provide a floor protector (hearth).

The dimensions given on the previous pages ("2.1. Positioning the Heater") are the minimum required for the floor protector to extend beyond the firebox door opening. It must extend no less than 300mm (B500) or 400mm (B800) in front of the door opening, no less than 200mm either side of the door opening, and extend under the heater.

MEASUREMENT	B500	B800
Door opening width	500mm	600mm
Minimum floor protector width	900mm	1000mm

It may be desirable, e.g. for aesthetic reasons, for the floor protector to be larger than these minimum dimensions.

The floor protector must be constructed of non-combustible material no less than 15mm thick and with a thermal conductivity not greater than 0.33W/m °K, e.g. compressed cement sheet.

The floor protector may be laid directly on the combustible floor.

For more details and variations on floor protectors refer to AS/NZS 2918:2018 Clause 2.2, 3.3.1, & 3.3.2.

3. REDUCING CLEARANCES TO COMBUSTIBLES

If it is necessary to install a heater closer to a combustible surface than the stated requirements in Section 3 of this Installation Guide, it must be done in accordance with Australian Standard AS/NZS 2918:2018 Section 3, Tables 3.1 & 3.2.

Shield Construction: The shield shall be constructed from a heat resistant material. The shield must be fixed to the surface that requires protection and NOT the heater.

The Standard allows three options to reduce stated clearances.

Single layer of continuous material with Minimum Air Gap of 12mm—Clearance Factor = 0.40

Single layer of continuous material with Minimum Air Gap of 25mm—Clearance Factor = 0.30

Two spaced layers of continuous material with Minimum Air Gaps of 12mm + 12mm—Clearance Factor = 0.20

The shielding must be open at the top and bottom (vented) to allow a continuous air flow. It is this air flow that keeps the surface requiring protection cool. Fixings should not impede this air flow.

The shielding needs to go far enough along and up the wall so that the original side and rear required clearances are not compromised. As the flue is now closer to the wall the shielding should also protect the wall from the flue pipe.

For example:

Side wall clearance for the B500 is 350 mm.

A 12mm gapped shield on the wall with a factor of 0.40.

Calculate: - 350 mm x 0.40 = 140 mm. This is the new side wall minimum clearance.

The shielding needs to be large enough so that none of the original clearances of 350 mm are compromised.

4. INSTALLING THE FLUE

The flue system used when installing the heater MUST comply with the current installation standard AS/NZS 2918.

Full instructions on the installation of the flue will be supplied with the flue kit. These MUST be followed closely, including the minimum exit height from the top of the floor protector being not less than 4.6m, and the minimum exit height above the roof line of roof ridge as detailed in the instructions.

The flue must be fitted with one of the following:

1. Rear Flue Shield:
 - a. 900 mm long, minimum 160° arc, stainless steel painted black rear flue shield with 25mm gap between it and the 150mm diameter active flue, and 25mm above the top of the heater.
2. Solid Flue Shield:

Note: MUST be installed with the manufacturer's ventilated decro-mesh locating ring.

- a. Full length solid outer flue shield casing (7.75" diameter) extending from the heater through into drop box penetrating the ceiling.
- b. The manufacturer's decro-mesh 'locating ring' must be used to support the flue shielding up off the heater top. It is important that air can be drawn into the base and rear of the flue shielding.
- c. Place the locating ring above the flue spigot (resting on the top plate) and then place the first length of 150mm active flue into the spigot. Slide the shielding over the active flue. Locate the bottom of the shielding inside the locating ring.

3. Decro-mesh:

Note: MUST be installed with the manufacturer's 490mm tall inner flue shield AND ventilated decro-mesh locating ring.

- a. A full length, half radius perforated decro-mesh flue shield extending from the heater through into the drop box penetrating the ceiling with the perforated surface facing the front (7.75" diameter)
- b. The 490 mm half round stainless steel inner reflector supplied with heater must be fitted inside the decro-mesh.
- c. The manufacturer's decro-mesh 'locating ring' must be used to support the flue shielding and inner shield up off the heater top. It is important that air can be drawn into the base and rear of the flue shielding.
- d. Place the locating ring above the flue spigot (resting on the top plate) and then place the first length of 150mm active flue into the spigot. With the 490mm inner shield fitted inside the decro-mesh, slide the shielding over the active flue. Locate the bottom of the decromesh and inner shield inside the locating ring.

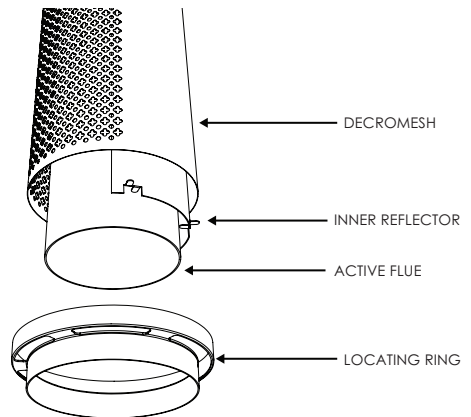
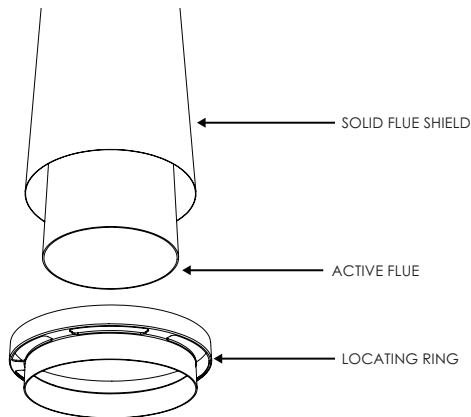

5. INSTALLING THE FLUE (CONTINUED)

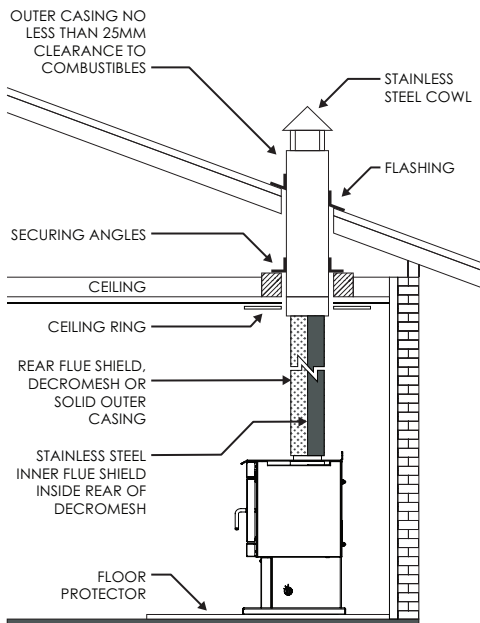

5.1. LOCATING RING

Depending on the supplier, the flue shielding can be one of three sizes – 200 mm, 7 ¾ inch, or 8 inch diameter. The decro-mesh ring will fit the two smaller diameters but not the 8 inch. In this scenario, snip through the outer ring with tin-snips as shown in the drawing below. Bend the two “arms” in a little so they ends don't project out when fitted to the decro-mesh. Ensure that the snipped section is at the rear of the flue, out of sight.

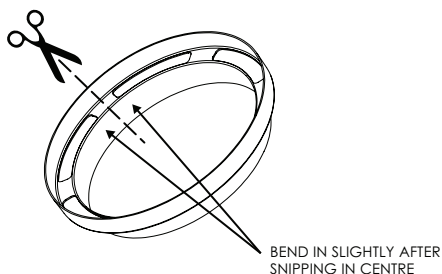

5.2. FITTING FLUE SEAL

Any gaps between the inside of the flue spigot and the active flue should be sealed. This can be done by wrapping the bottom of the flue with the length of fibreglass tape supplied. Alternatively, high temperature stove cement can also be used.

6. INSTALLING THE ASH PLATE

The ash plate acts to protect the front of the firebox below the door opening from the hot coal bed and fire.

When positioning the ash plate, ensure that the front face is flush with the door opening face, as shown in the following diagrams

7. INSTALLING THE BAFFLE PLATE

The baffle plate should be installed before installing the fire bricks.

1. Place the baffle plate inside the firebox, oriented as per the following diagrams.

B500:

Ensure the larger of the two folds is positioned to the front of the heater.

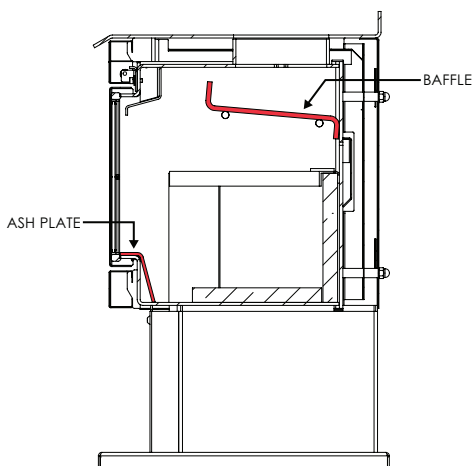

B800:

Ensure the fold is placed to the rear of the heater, and the welded railing to the front.

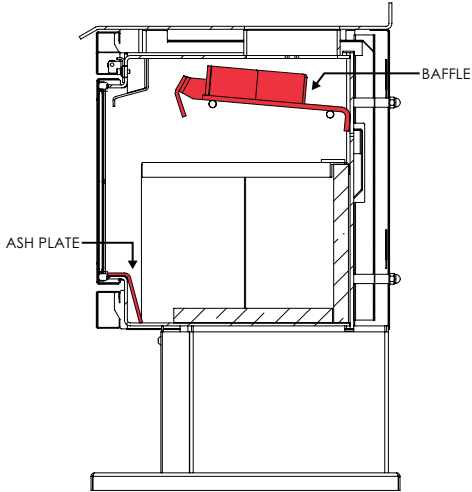

2. Raise the front of the baffle and place it above the front pins from behind.
3. Raise the rear of the baffle, sliding it forward enough to clear the pins at the rear. Lift the rear of the baffle plate up and over the rear pins.
4. Push baffle hard up against rear of firebox

8. INSTALLING THE FIRE BRICKS

Place the bricks into the firebox as shown in the diagrams below for the B500 and B800. Once bricks are in, fit the retainer over the top to hold them in place.

B500:

- Two full size (220 x 175 x 25) and one (220 x 140 x 25) along the back.
- One full size and one half size (220 x 85 x 25) along each side.
- Two full size and one half size in the base.

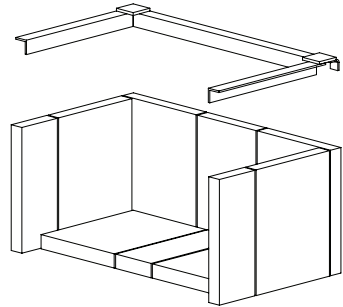
**B800:**

- Three full size (270 x 175 x 25) along the back.
- Two full size along each side.
- Three full size in the base.

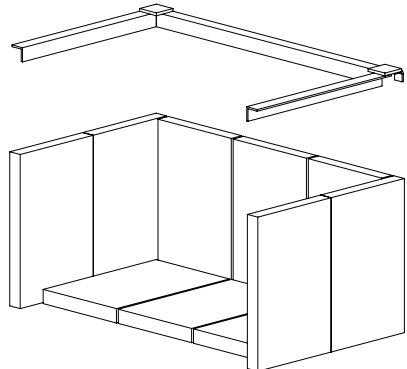

9. TECHNICAL DRAWINGS

9.1. B500

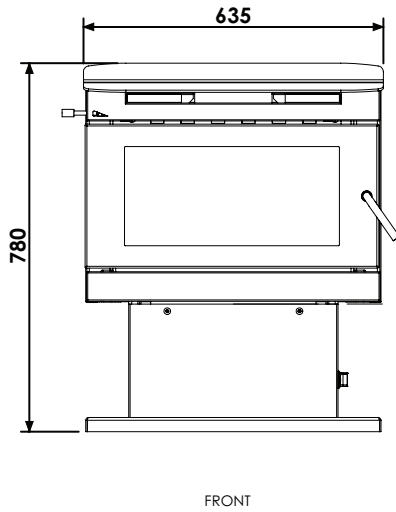
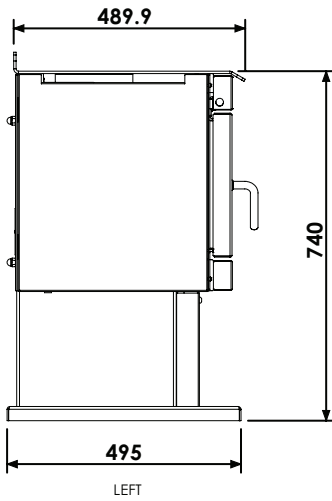
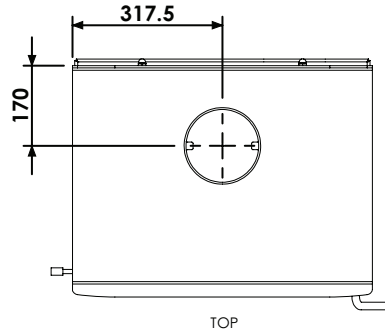

9.2. B800

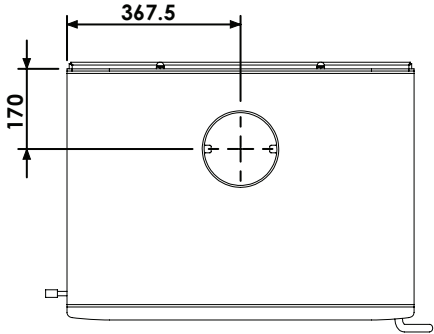

TOP

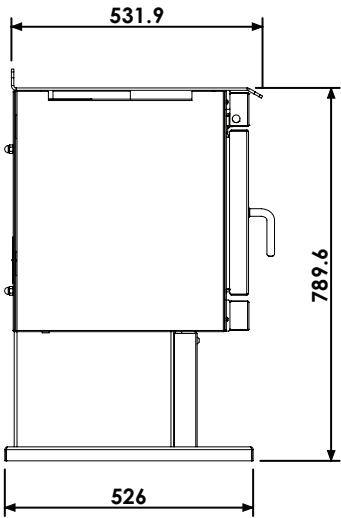

LEFT

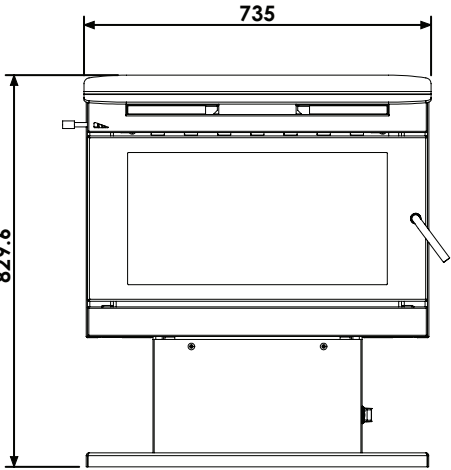

FRONT



Glen Dimplex Australia Pty Ltd

8 Lakeview Drive,
Scoresby Victoria 3179
Australia

T: 1300 554 155

General & Sales Enquiries: flame.care@glendimplex.com.au

Technical Service: flame.support@glendimplex.com.au

www.glendimplex.com.au