



blaze

B400
PORTRAIT WOOD HEATER

INSTALLATION INSTRUCTIONS

Contemporary Styled Wood Heaters



BLAZE B400



Glen Dimplex Australia proudly supports the activities of Landcare Australia through its membership of the AHHA.

VERSION 1.2

TABLE OF CONTENTS

- 1. Important Information. 2
- 2. Installing the Heater 3
 - 2.1. Positioning the Heater. 3
 - 2.1.1. Standard Installation 3
 - 2.1.2. Corner Installation 3
 - 2.2. Floor Protector (Hearth) 4
- 3. Reducing Clearances to Combustibles 4
- 4. Installing the Flue. 5
- 5. Installing the Flue (Continued) 6
 - 5.1. Fitting Flue Seal 6
- 6. Installing the Fire Bricks 6
- 7. Installing the Baffle Plate 7
- 8. Technical Drawings. 8

THE INSTALLATION INSTRUCTIONS IN THIS MANUAL APPLY TO THE BLAZE B400.

IT HAS BEEN TESTED FOR EMISSIONS AND EFFICIENCY AND COMPLIES ACCORDING TO AS/NZS 4012:2014 & AS/NZS 4013:2014.

INSTALLATION CLEARANCES WERE DETERMINED BY TESTING IN ACCORDANCE WITH AS/NZS 2918.

1. IMPORTANT INFORMATION

Most building regulatory authorities in Australia require any wood heater installation to comply with Installation Standard AS/NZS 2918:2018. Different states and councils may have varying regulations. Check local building regulations before installing the appliance.

All Blaze wood heaters have been tested to ensure that they will meet the appropriate safety Standard requirements if the instructions in this manual are followed. As the safety and emissions performance can be affected by altering the appliance, no modifications are allowed without written permission from the manufacturer.

WE RECOMMEND THAT THE INSTALLATION OF YOUR BLAZE WOOD HEATER BE CARRIED OUT BY A QUALIFIED INSTALLER.

WARNING: THE APPLIANCE AND FLUE SYSTEM SHALL BE INSTALLED IN ACCORDANCE WITH AS/NZS 2918:2018 AND THE APPROPRIATE REQUIREMENTS OF THE RELEVANT BUILDING CODE OR CODES.

WARNING: APPLIANCES INSTALLED IN ACCORDANCE WITH THIS STANDARD SHALL COMPLY WITH THE REQUIREMENTS OF AS/NZS 4012 & AS/NZS 4013 WHERE REQUIRED BY THE REGULATORY AUTHORITY, I.E. THE APPLIANCE SHALL BE IDENTIFIABLE BY A COMPLIANCE PLATE WITH THE MARKING 'TESTED TO AS/NZS 4012 & AS/NZS 4013'.

ANY MODIFICATION OF THE APPLIANCE THAT HAS NOT BEEN APPROVED IN WRITING BY THE TESTING AUTHORITY IS CONSIDERED TO BE IN BREACH OF THE APPROVAL GRANTED FOR COMPLIANCE WITH AS/NZS 4012 & AS/NZS 4013.

Caution: Mixing of appliance or flue-system components from different sources or modifying the dimensional specification of components may result in hazardous conditions. Where such action is considered, the manufacturer should be consulted in the first instance.

Caution: Cracked and broken components, e.g. glass panels or ceramic tiles, may render the installation unsafe.

WARNING: KEEP BATTERIES OUT OF REACH OF CHILDREN

Swallowing may lead to serious injury in as little as 2 hours or death, due to chemical burns and potential perforation of the oesophagus.

If you suspect your child has swallowed or inserted a button battery immediately call the 24-hour Poisons Information Centre on 13 11 26 (in Australia) or 0800 764 766 (in New Zealand) for fast, expert advice.

Examine devices and make sure the battery compartment is correctly secured, e.g. that the screw or other mechanical fastener is tightened. Do not use if the compartment is not secure.

Dispose of used button batteries immediately and safely. Flat batteries can still be dangerous.



2. INSTALLING THE HEATER

2.1. POSITIONING THE HEATER

First review the necessary **minimum** clearances specified on the following page before considering where to position the heater. These clearances can be greater if desired. The heater can be installed with one of two different flue configurations. Clearances specific to each are listed in the associated tables. Also check the practicability of installing the flue system in relation to any obstructing roof beams before positioning the heater.

These clearance distances can only be reduced if the surrounding walls are made of non-combustible material, e.g. stone, brick, or concrete. In this circumstance, distance can be reduced to 100 mm. Alternatively, shielding of the wall(s) can reduce clearances (refer to next section for more detail).

NOTE: 150mm rear clearance is required in a Standard Installation if ever the fan needs to be removed. If this rear clearance is reduced, the appliance will need to be moved forward to be able to remove the fan should it require servicing.

2.1.1. STANDARD INSTALLATION

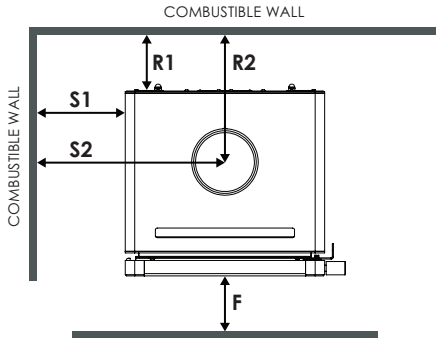

2.1.2. CORNER INSTALLATION

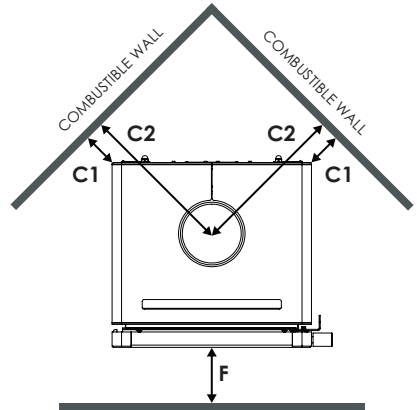

CLEARANCES STANDARD INSTALLATION

	SINGLE SHIELD	DECRO/SOLID
Side - S1	400mm	400mm
Side - S2	661mm	661mm
Rear - R1	100mm	150mm
Rear - R2	286mm	336mm
Floor - F	300mm	300mm

CLEARANCES CORNER INSTALLATION

	SINGLE SHIELD	DECRO/SOLID
Corner - C1	175mm	200mm
Corner - C2	490mm	515mm
Floor - F	300mm	300mm

2.2. FLOOR PROTECTOR (HEARTH)

Unless the heater will be standing on a heat resistant floor such as concrete slab with slate or tiles, it will be necessary to provide a floor protector (hearth).

The dimensions given on the previous page ("2.1. Positioning the Heater") are the minimum required for the floor protector to extend beyond the firebox door opening. It must extend no less than 300mm in front of the door opening, no less than 200mm either side of the door opening, and extend under the heater.

MEASUREMENT	WIDTH
Door opening width	420mm
Minimum floor protector width	820mm

It may be desirable, e.g. for aesthetic reasons, for the floor protector to be larger than these minimum dimensions.

The floor protector must be constructed of non-combustible material in accordance with AS/NZS 2918.

The floor protector may be laid directly on the combustible floor.

For more details and variations on floor protectors refer to AS/NZS 2918:2018 Clause 2.2, 3.3.1, & 3.3.2.

3. REDUCING CLEARANCES TO COMBUSTIBLES

If it is necessary to install a heater closer to a combustible surface than the stated requirements in Section 2 of this Installation Guide, it must be done in accordance with Australian Standard AS/NZS 2918:2018 Section 3, Tables 3.1 & 3.2.

Shield Construction: The shield shall be constructed from a heat resistant material. The shield must be fixed to the surface that requires protection and NOT the heater.

The Standard allows three options to reduce stated clearances.

Single layer of continuous material with Minimum Air Gap of 12mm—Clearance Factor = 0.40

Single layer of continuous material with Minimum Air Gap of 25mm—Clearance Factor = 0.30

Two spaced layers of continuous material with Minimum Air Gaps of 12mm + 12mm—Clearance Factor = 0.20

The shielding must be open at the top and bottom (vented) to allow a continuous air flow. It is this air flow that keeps the surface requiring protection cool. Fixings should not impede this air flow.

The shielding needs to go far enough along and up the wall so that the original side and rear required clearances are not compromised. As the flue is now closer to the wall the shielding should also protect the wall from the flue pipe.

For example:

Side wall clearance for the B400 is 400mm.

A 12mm gapped shield on the wall with a factor of 0.40.

Calculate: $400\text{mm} \times 0.40 = 160\text{mm}$. This is the new side wall minimum clearance.

The shielding needs to be large enough so that none of the original clearances of 400mm are compromised.

4. INSTALLING THE FLUE

The flue system used when installing the heater MUST comply with the current installation standard AS/NZS 2918.

Full instructions on the installation of the flue will be supplied with the flue kit. These MUST be followed closely, including the minimum exit height from the top of the floor protector being not less than 4.6m, and the minimum exit height above the roof line or roof ridge as detailed in the instructions.

The flue must be fitted with one of the following:

1. Rear Flue Shield:

- a. 900 mm long, minimum 160° arc, stainless steel painted black rear flue shield with 25mm gap between it and the 150mm diameter active flue, and 25mm above the top of the heater.

2. Decromesh / Solid Flue Shield:

Note - must be installed with an internal heat shield/reflector AND ventilated decromesh locating ring.

- a. A full length, half radius perforated decromesh flue shield extending from the heater through into the drop box penetrating the ceiling with the perforated surface facing the front, OR equivalent in solid outer flue shield casing (7.75" diameter)
- b. The internal heat shield/reflector must be a minimum of 900mm tall and must be fitted inside the decro-mesh or solid outer flue shield.
- c. The manufacturer's decromesh 'locating ring' must be used to support the flue shielding and inner shield up off the heater top. It is important that air can be drawn into the base and rear of the flue shielding.

- d. Place the locating ring above the flue spigot (resting on the top plate) and then place the first length of 150mm active flue into the spigot. With the inner shield fitted inside the decromesh or solid outer shield, slide the shielding over the active flue. Locate the bottom of the decromesh or solid outer shield and inner shield inside the locating ring.

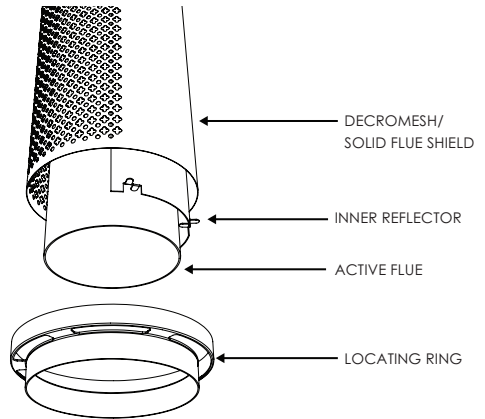

- e. Depending on the supplier, the flue shielding can be one of three sizes – 200 mm, 7 ¾ inch, or 8 inch diameter. The locating ring will fit the two smaller diameters but not the 8 inch. In this scenario, snip through the outer ring with tin-snips as shown in the drawing below. Bend the two "arms" in a little so they ends don't project out when fitted to the decromesh. Ensure that the snipped section is at the rear of the flue, out of sight.

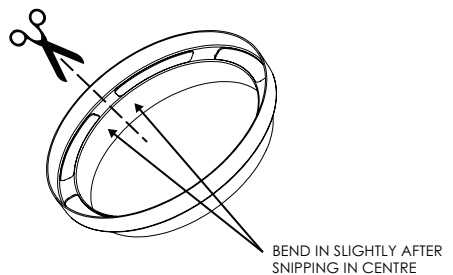

5. INSTALLING THE FLUE (CONTINUED)

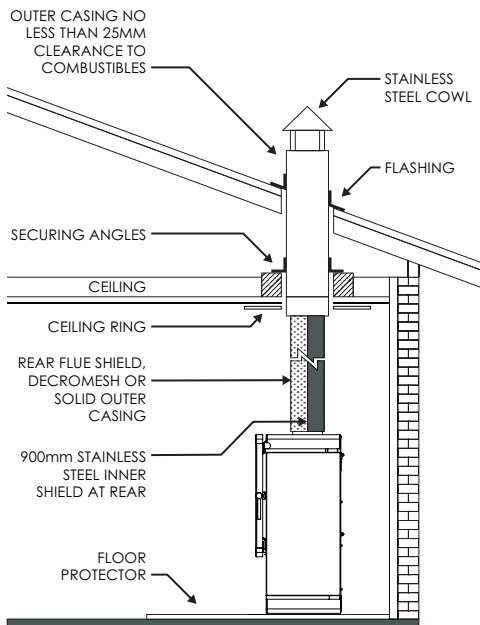

5.1. FITTING FLUE SEAL

Any gaps between the inside of the flue spigot and the active flue should be sealed. This can be done by wrapping the bottom of the flue with the length of fibreglass tape supplied. Alternatively, high temperature stove cement can also be used.

6. INSTALLING THE FIRE BRICKS

Place the bricks into the firebox as shown in the diagram below for the B400. Once bricks are in, fit the retainers over the top to hold them in place.

- Two (270 x 207 x 25) bricks along the back.
- One (270 x 207 x 25) and one (270 x 100 x 25) along each side.

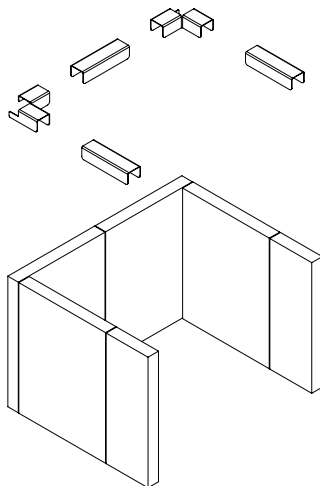

7. INSTALLING THE BAFFLE PLATE

1. Slide rear baffle retainer onto baffle, then place the baffle inside the firebox.
2. Raise the baffle, tilting the right side upwards.
3. Raise the right side of the baffle over the right baffle rail. Once clear of the right rail, push the baffle to the right side of the heater in order to clear the left baffle rail.
4. Once resting on both baffle rails, centralise the baffle so that gaps between each side and firebox are equal.
5. Install front baffle retainer onto baffle.

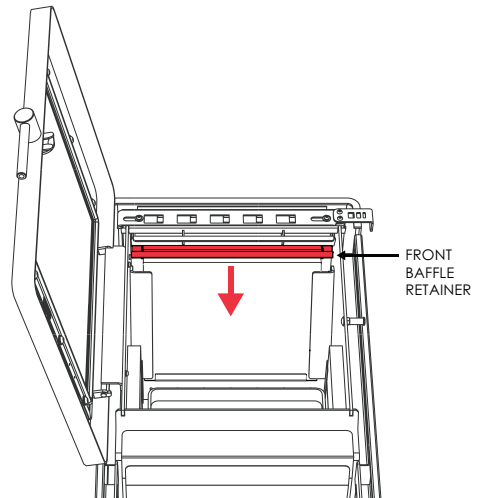
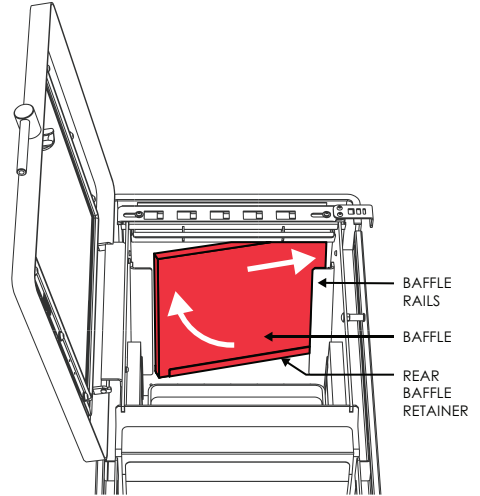
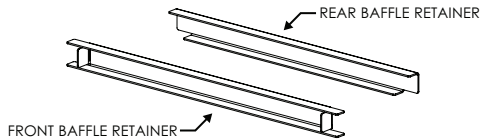

8. TECHNICAL DRAWINGS

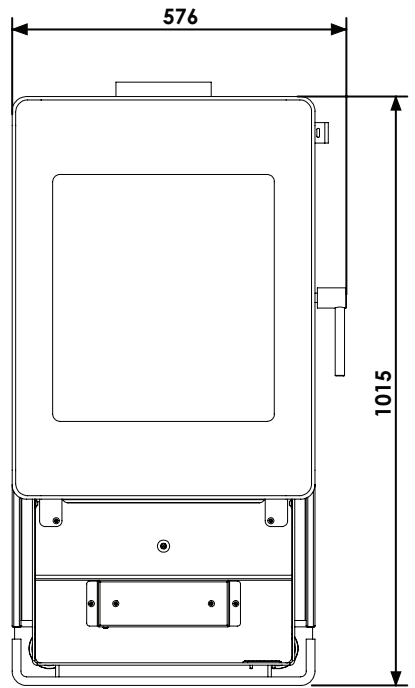
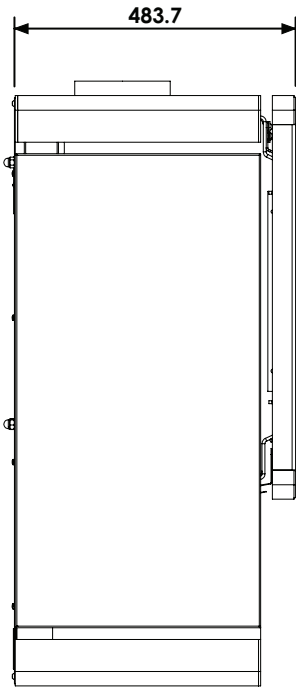
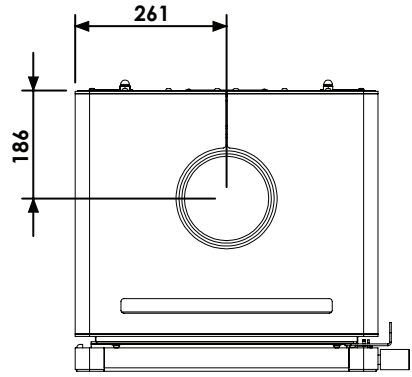



Glen Dimplex Australia Pty Ltd

8 Lakeview Drive,
Scoresby Victoria 3179
Australia

T: 1300 554 155

General & Sales Enquiries: flame.care@glendimplex.com.au

Technical Service: flame.support@glendimplex.com.au

www.glendimplex.com.au